



AGS5500

Air curtain for doors in industrial and large premises, with intelligent control

- Recommended installation height 5,5 m*
- Horizontal mounting
- Lengths: 1,5, 2, 2,5 and 3 m
- ✿ Ambient, no heat
- 💧 Water heat WH, WL

Application

AGS5500 is a powerful air curtain intended for industrial doors but it can also be used for entryways in other large premises such as shopping malls.

With its many clever, energy saving functions, the air curtain gives effective protection, specially adapted for your door.

Design

AGS has a timeless, clean design. The air curtain is intended for horizontal installation, models for vertical and recessed installation are available for special order.



Optimized airflow with Thermozone technology.

Air velocity profile

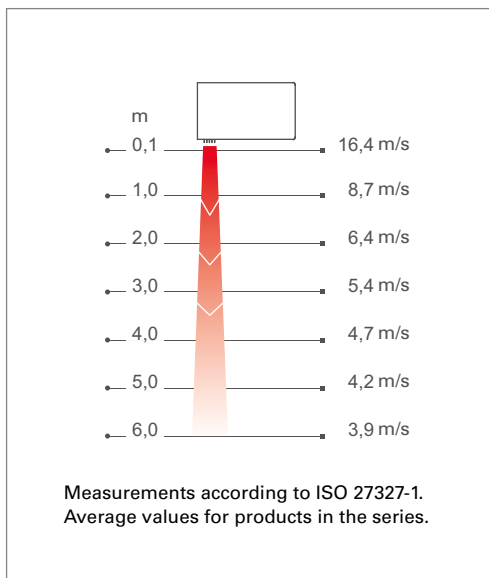

Product specifications

- Prepared for the SIRE control system whose pre-programmed default settings and many features make it easy to install and use the air curtain. Read more about the SIRE controls package in the "Controls" section.
- The following models are available for special order:
 - with electrical heating
 - with alternative water connections
 - for vertical installation
 - for recessed installation in suspended ceilings
- Intake grilles that can be opened make it easy to access the water coil. The grille is easy to clean from the outside.
- Adjustable outlet grille makes it possible to direct the air for optimum air curtain effect.
- Corrosion proof housing made of hot zinc-plate and powder enamelled steel panels. Colour: white, RAL 9016, NCS S 0500-N. Colour grille: grey, RAL 7046.

*) Recommended installation height varies depending on the relevant premises.

Technical specifications

✿ Ambient, no heat - AGS5500 A

Type	Output [kW]	Airflow*1 [m ³ /h]	Sound level*2 [dB(A)]	Voltage motor [V]	Amperage motor [A]	Length [mm]	Weight [kg]
AGS5515A	0	2500/5800	51/70	230V~	8,1	1515	109
AGS5520A	0	3750/8700	52/72	230V~	12,1	2010	144
AGS5525A	0	5000/11600	53/73	230V~	16,2	2520	183
AGS5530A	0	6250/14500	55/74	230V~	20,3	3030	218

💧 Water heat - AGS5500 WH, coil for high temperature water (≥80 °C)

Type	Output*4 [kW]	Airflow*1 [m ³ /h]	Δt*3,4 [°C]	Water volume [l]	Sound level*2 [dB(A)]	Voltage motor [V]	Amperage motor [A]	Length [mm]	Weight [kg]
AGS5515WH	34	2500/5500	25/18	3,8	50/70	230V~	7,7	1515	129
AGS5520WH	57	3750/8250	27/20	4,9	51/71	230V~	11,6	2010	169
AGS5525WH	74	5000/11000	27/20	6,4	52/72	230V~	15,4	2520	213
AGS5530WH	92	6250/13750	27/20	7,6	54/74	230V~	19,3	3030	258

💧 Water heat - AGS5500 WL, coil for low water temperature (≤80 °C)

Type	Output*4 [kW]	Airflow*1 [m ³ /h]	Δt*3,4 [°C]	Water volume [l]	Sound level*2 [dB(A)]	Voltage motor [V]	Amperage motor [A]	Length [mm]	Weight [kg]
AGS5515WL	26	2500/5500	19/14	4,0	50/70	230V~	7,7	1515	129
AGS5520WL	45	3750/8250	22/16	8,1	51/71	230V~	11,6	2010	169
AGS5525WL	59	5000/11000	21/16	9,2	52/72	230V~	15,4	2520	213
AGS5530WL	71	6250/13750	20/15	11,0	54/74	230V~	19,3	3030	258

*1) Lowest/highest airflow of totally 5 fan steps.

*2) Conditions: Distance to the unit 5 metres. Directional factor: 2. Equivalent absorption area: 200 m². At lowest/highest airflow.

*3) Δt = temperature rise of passing air at maximum heat output and lowest/highest airflow.

*4) Applicable at water temperature 80/60 °C, air temperature, in +18 °C.

*5) Applicable at water temperature 60/40 °C, air temperature, in +18 °C.

Models 1,5m – 2,5m approved for 220V/1ph/60Hz are available on request. Product performance for 220V/1ph/60Hz will differ from stated data.

Protection class: IP24.

CE compliant.

AGS5500

Dimensions

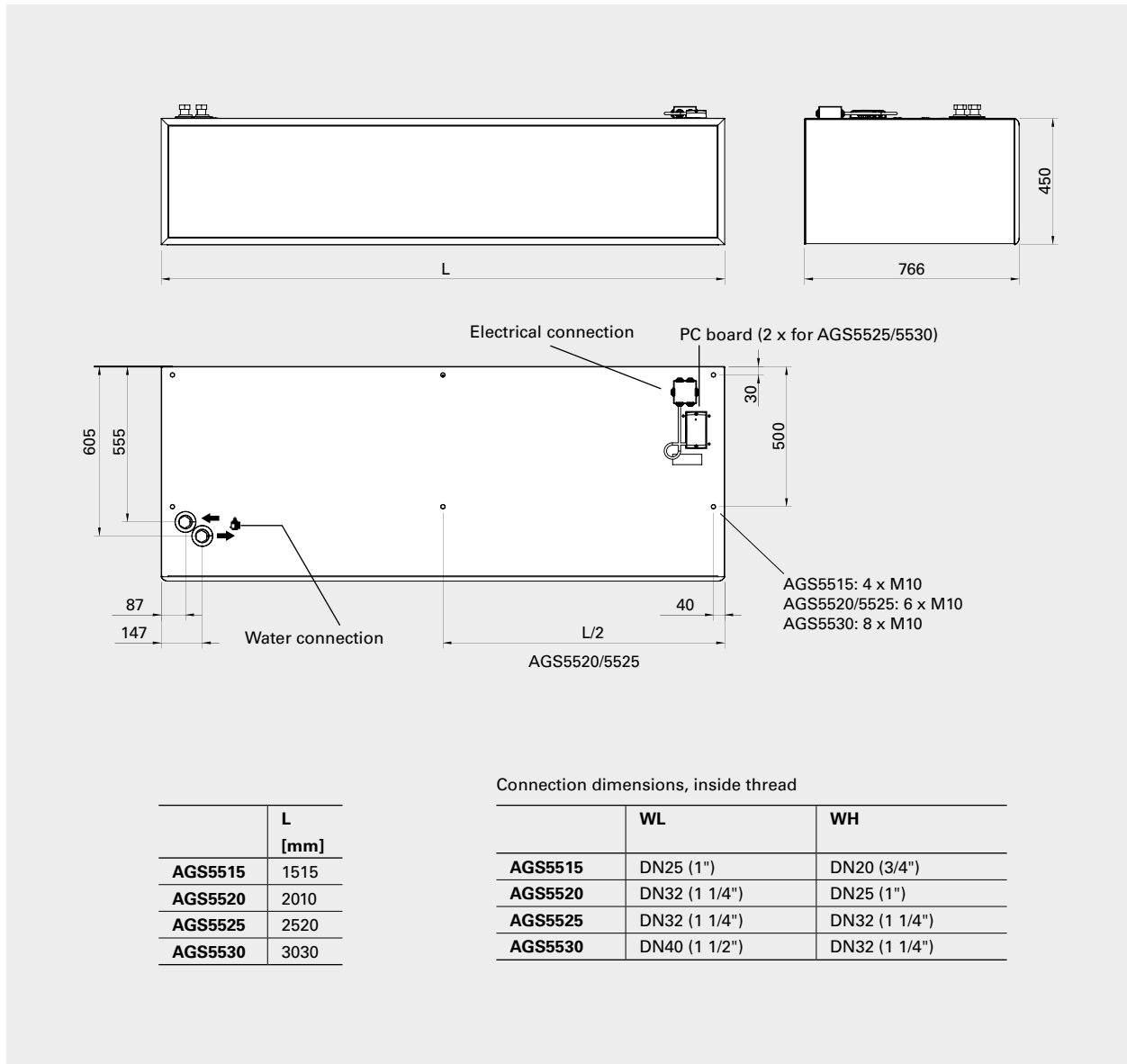

	L [mm]
AGS5515	1515
AGS5520	2010
AGS5525	2520
AGS5530	3030

Connection dimensions, inside thread

	WL	WH
AGS5515	DN25 (1")	DN20 (3/4")
AGS5520	DN32 (1 1/4")	DN25 (1")
AGS5525	DN32 (1 1/4")	DN32 (1 1/4")
AGS5530	DN40 (1 1/2")	DN32 (1 1/4")

Mounting and connection

Mounting

The air curtain is installed horizontally with the supply air grille facing downwards as close to the door as possible. A variety of installation options are available; brackets for wall mounting or threaded bars for ceiling mounting.

Design kit for an installation with concealed mountings, cables and pipes is available as an option.

For the protection of wider doorways, several units can be mounted next to each other.

Connection

The PC board SIRE is built into the air curtain on delivery and is equipped with modular connectors for easy connection of external components. Read more about the SIRE control system in the "Controls" section.

Unit without heating

Operation (230V~) is connected to terminal block in the junction box on top of the unit.

Unit with water heating

Operation (230V~) is connected to terminal block in the junction box on top of the unit.

The water coil is connected via connections with dimensions as given in the table (see diagram) on top of the unit.

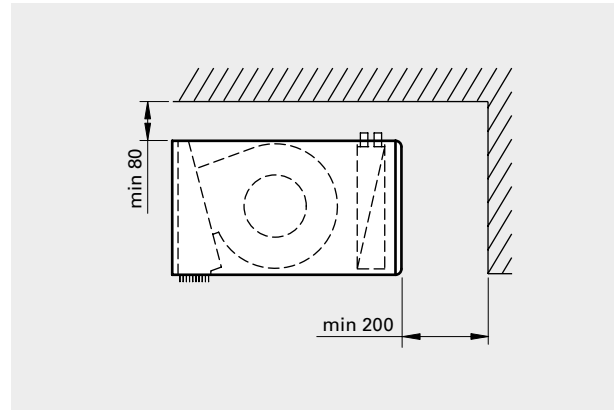

Minimum distances



Accessories

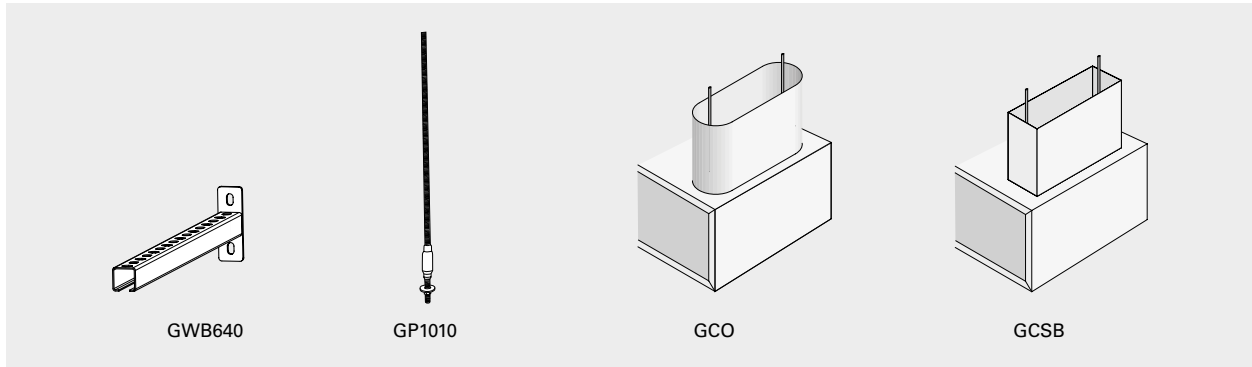

GWB640, wall bracket

Brackets for installing unit horizontally on a wall. Two are required for 1 and 1.5 metre units, while 2 and 2.5 metre units need three and 3 metre units need four.

GP1010, threaded bar

Threaded bar for mounting in ceilings. Length 1 m. M10. Four are required for 1 and 1.5 metre units, while 2 and 2.5 metre units need six and 3 metre units need eight.

GCO, oval design kit

Used to conceal mountings, cables and pipes. Special order to required dimension.

GCSB, square design kit

Used to conceal mountings, cables and pipes. Special order to required dimension.

Type	Description	Quantity included	Length
GWB640	Wall bracket	1 pc	400 mm
GP1010	Threaded bar	1 pc	1 m
GCO	Oval design kit		
GCSB	Square design kit		

Controls



This air curtain is supplied with an integrated PC board SIRE. There are three different levels with different functionality to choose from, Basic, Competent or Advanced. Read more about the SIRE control system in the "Controls" section.

Type	Description
SIReBN	Control system SIRe Basic
SIReACY	Control system SIRe Competent
SIReAAY	Control system SIRe Advanced

Water control

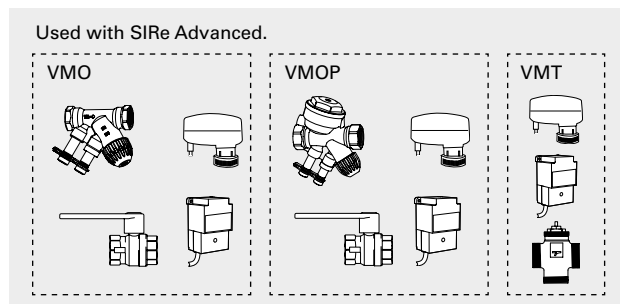
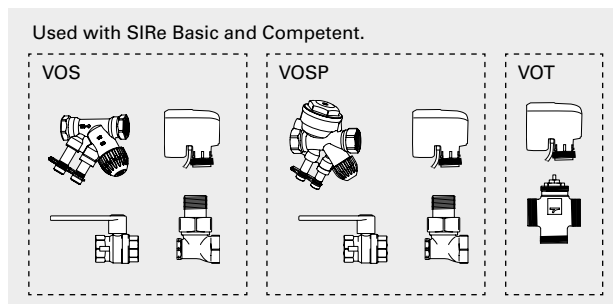

Valve kit VOS(P), VOT, VMO(P) or VMT is used to control the water flow. For more information see the "Controls" section.

Type	Description
VOS15LF	Valve kit on/off, low flow, DN15
VOS15NF	Valve kit on/off, DN15
VOS20	Valve kit on/off, DN20
VOS25	Valve kit on/off, DN25
VOSP15LF	Pressure independent valve kit, low flow, DN15
VOSP15NF	Pressure independent valve kit, DN15
VOSP20	Pressure independent valve kit, DN20
VOSP25	Pressure independent valve kit, DN25
VOT15	Three way control valve and actuator on/off, DN15
VOT20	Three way control valve and actuator on/off, DN20
VOT25	Three way control valve and actuator on/off, DN25

Type	Description
VMO15LF	Modulating valve kit, low flow, DN15
VMO15NF	Modulating valve kit, DN15
VMO20	Modulating valve kit, DN20
VMO25	Modulating valve kit, DN25
VMOP15LF	Pressure independent and modulating valve kit, low flow, DN15
VMOP15NF	Pressure independent and modulating valve kit, DN15
VMOP20	Pressure independent and modulating valve kit, DN20
VMOP25	Pressure independent and modulating valve kit, DN25
VMT15	Three way control valve and modulating actuator, DN15
VMT20	Three way control valve and modulating actuator, DN20
VMT25	Three way control valve and modulating actuator, DN25

Output charts water

			Supply water temperature: 110 °C Room temperature: +18 °C Outlet air temperature: +35 °C*1				Water temperature: 110/80 °C Room temperature: +18 °C			
Type	Fan position	Airflow [m³/h]	Output [kW]	Return water temp. [°C]	Water flow [l/s]	Pressure drop [kPA]	Output*2 [kW]	Outlet air temp. [°C]	Water flow [l/s]	Pressure drop [kPA]
AGS5515WH	max	5500	32	47	0,13	1,2	51	45	0,42	10,9
	min	2500	14	34	0,05	0,2	31	55	0,26	4,4
AGS5520WH	max	8250	48	42	0,17	0,8	85	48	0,70	10,7
	min	3750	22	32	0,07	0,1	52	59	0,43	4,2
AGS5525WH	max	11000	62	42	0,22	0,7	111	48	0,92	10,0
	min	5000	29	33	0,09	0,1	68	58	0,56	3,9
AGS5530WH	max	13750	80	47	0,31	1,0	138	48	1,14	10,6
	min	6250	36	37	0,12	0,2	87	59	0,72	4,5

			Supply water temperature: 90 °C Room temperature: +18 °C Outlet air temperature: +35 °C*1				Water temperature: 90/70 °C Room temperature: +18 °C			
Type	Fan position	Airflow [m³/h]	Output [kW]	Return water temp. [°C]	Water flow [l/s]	Pressure drop [kPA]	Output*2 [kW]	Outlet air temp. [°C]	Water flow [l/s]	Pressure drop [kPA]
AGS5515WH	max	5500	32	52	0,20	2,9	41	40	0,51	16,1
	min	2500	15	39	0,07	0,4	26	48	0,31	6,5
AGS5520WH	max	8250	48	47	0,28	1,9	69	43	0,85	15,8
	min	3750	22	36	0,10	0,3	42	51	0,52	6,1
AGS5525WH	max	11000	63	47	0,36	1,7	90	42	1,11	14,7
	min	5000	29	36	0,13	0,3	55	51	0,68	5,7
AGS5530WH	max	13750	77	50	0,47	2,2	113	42	1,38	15,8
	min	6250	36	40	0,18	0,4	71	51	0,87	6,7

			Supply water temperature: 80 °C Room temperature: +18 °C Outlet air temperature: +35 °C*1				Water temperature: 80/60 °C Room temperature: +18 °C			
Type	Fan position	Airflow [m³/h]	Output [kW]	Return water temp. [°C]	Water flow [l/s]	Pressure drop [kPA]	Output*2 [kW]	Outlet air temp. [°C]	Water flow [l/s]	Pressure drop [kPA]
AGS5515WH	max	5500	33	58	0,35	8,3	34	36	0,41	11,2
	min	2500	14	40	0,09	0,6	21	43	0,26	4,5
AGS5520WH	max	8250	48	50	0,39	3,7	57	38	0,70	10,9
	min	3750	22	38	0,13	0,5	35	45	0,42	4,3
AGS5525WH	max	11000	62	50	0,51	3,3	74	38	0,91	10,1
	min	5000	29	38	0,17	0,4	46	45	0,56	4,0
AGS5530WH	max	13750	81	54	0,75	5,3	92	38	1,12	11,0
	min	6250	35	40	0,22	0,6	58	45	0,70	4,7

			Supply water temperature: 82 °C Room temperature: +18 °C Outlet air temperature: +35 °C*1				Water temperature: 82/71 °C Room temperature: +18 °C			
Type	Fan position	Airflow [m³/h]	Output [kW]	Return water temp. [°C]	Water flow [l/s]	Pressure drop [kPA]	Output*2 [kW]	Outlet air temp. [°C]	Water flow [l/s]	Pressure drop [kPA]
AGS5515WH	max	5500	31	54	0,27	5,1	40	39	0,89	47,9
	min	2500	14	40	0,08	0,6	25	47	0,55	19,0
AGS5520WH	max	8250	48	50	0,37	3,3	67	42	1,49	47,6
	min	3750	22	37	0,12	0,4	41	50	0,91	18,2
AGS5525WH	max	11000	63	50	0,48	3,0	88	42	1,96	44,8
	min	5000	29	38	0,16	0,4	54	50	1,19	17,1
AGS5530WH	max	13750	79	52	0,64	4,0	111	42	2,47	47,1
	min	6250	36	40	0,21	0,5	70	51	1,55	19,6

*1) Recommended outlet air temperature for good comfort and optimized output.

*2) Nominal output at given supply and return water temperature.

Output charts water

			Supply water temperature: 80 °C Room temperature: +18 °C Outlet air temperature: +35 °C*1				Water temperature: 80/60 °C Room temperature: +18 °C			
Type	Fan position	Airflow [m³/h]	Output [kW]	Return water temp. [°C]	Water flow [l/s]	Pressure drop [kPA]	Output*2 [kW]	Outlet air temp. [°C]	Water flow [l/s]	Pressure drop [kPA]
AGS5515WL	max	5500	31	40	0,19	1,3	47	43	0,58	9,8
	min	2500	14	33	0,07	0,2	28	51	0,35	3,7
AGS5520WL	max	8250	49	34	0,26	2,4	78	46	0,95	27,3
	min	3750	21	26	0,09	0,4	47	55	0,57	10,4
AGS5525WL	max	11000	64	34	0,34	4,4	100	45	1,22	49,1
	min	5000	29	26	0,13	0,8	61	54	0,74	18,7
AGS5530WL	max	13750	78	36	0,44	4,9	124	45	1,51	43,2
	min	6250	35	29	0,17	0,9	73	52	0,89	16,6

			Supply water temperature: 70 °C Room temperature: +18 °C Outlet air temperature: +35 °C*1				Water temperature: 70/50 °C Room temperature: +18 °C			
Type	Fan position	Airflow [m³/h]	Output [kW]	Return water temp. [°C]	Water flow [l/s]	Pressure drop [kPA]	Output*2 [kW]	Outlet air temp. [°C]	Water flow [l/s]	Pressure drop [kPA]
AGS5515WL	max	5500	32	44	0,30	2,9	37	38	0,45	6,2
	min	2500	14	35	0,10	0,4	22	44	0,27	2,4
AGS5520WL	max	8250	48	38	0,36	4,5	62	40	0,75	17,7
	min	3750	22	28	0,13	0,7	37	47	0,46	6,8
AGS5525WL	max	11000	63	38	0,47	8,2	80	39	0,97	31,8
	min	5000	29	28	0,17	1,3	49	47	0,59	12,3
AGS5530WL	max	13750	81	41	0,67	10,6	98	39	1,19	28,9
	min	6250	36	32	0,23	1,6	58	45	0,70	11,2

			Supply water temperature: 60 °C Room temperature: +18 °C Outlet air temperature: +35 °C*1				Water temperature: 60/40 °C Room temperature: +18 °C			
Type	Fan position	Airflow [m³/h]	Output [kW]	Return water temp. [°C]	Water flow [l/s]	Pressure drop [kPA]	Output*2 [kW]	Outlet air temp. [°C]	Water flow [l/s]	Pressure drop [kPA]
AGS5515WL	max	5500	33	48	0,63	11,9	27	32	0,32	3,4
	min	2500	15	37	0,16	0,9	16	37	0,19	1,3
AGS5520WL	max	8250	48	42	0,67	14,4	46	34	0,55	10,1
	min	3750	21	31	0,18	1,2	28	40	0,34	4,0
AGS5525WL	max	11000	65	45	1,06	38,2	59	34	0,72	18,1
	min	5000	30	32	0,26	2,7	36	39	0,44	7,2
AGS5530WL	max	13750	81	45	1,30	35,0	71	33	0,87	17,0
	min	6250	36	35	0,35	3,4	42	38	0,51	6,7

			Supply water temperature: 55 °C Room temperature: +18 °C Outlet air temperature: +35 °C*1				Water temperature: 55/35 °C Room temperature: +18 °C			
Type	Fan position	Airflow [m³/h]	Output [kW]	Return water temp. [°C]	Water flow [l/s]	Pressure drop [kPA]	Output*2 [kW]	Outlet air temp. [°C]	Water flow [l/s]	Pressure drop [kPA]
AGS5515WL	max	5500	32	48	1,14	37,4	21	29	0,26	2,2
	min	2500	14	38	0,21	1,5	13	33	0,15	0,9
AGS5520WL	max	8250	49	46	1,31	52,4	37	31	0,45	7,0
	min	3750	21	32	0,23	2,0	23	36	0,28	2,8
AGS5525WL	max	11000	62	46	1,68	94,3	49	31	0,59	12,6
	min	5000	29	34	0,33	4,2	30	36	0,36	5,1
AGS5530WL	max	13750	78	46	2,10	83,9	58	30	0,70	12,0
	min	6250	37	37	0,49	6,4	34	34	0,42	4,8

*1) Recommended outlet air temperature for good comfort and optimized output.

*2) Nominal output at given supply and return water temperature.

See www.frico.se for additional calculations.

AGS5500

Wiring diagrams

Internal wiring diagram

AGS5515/5520

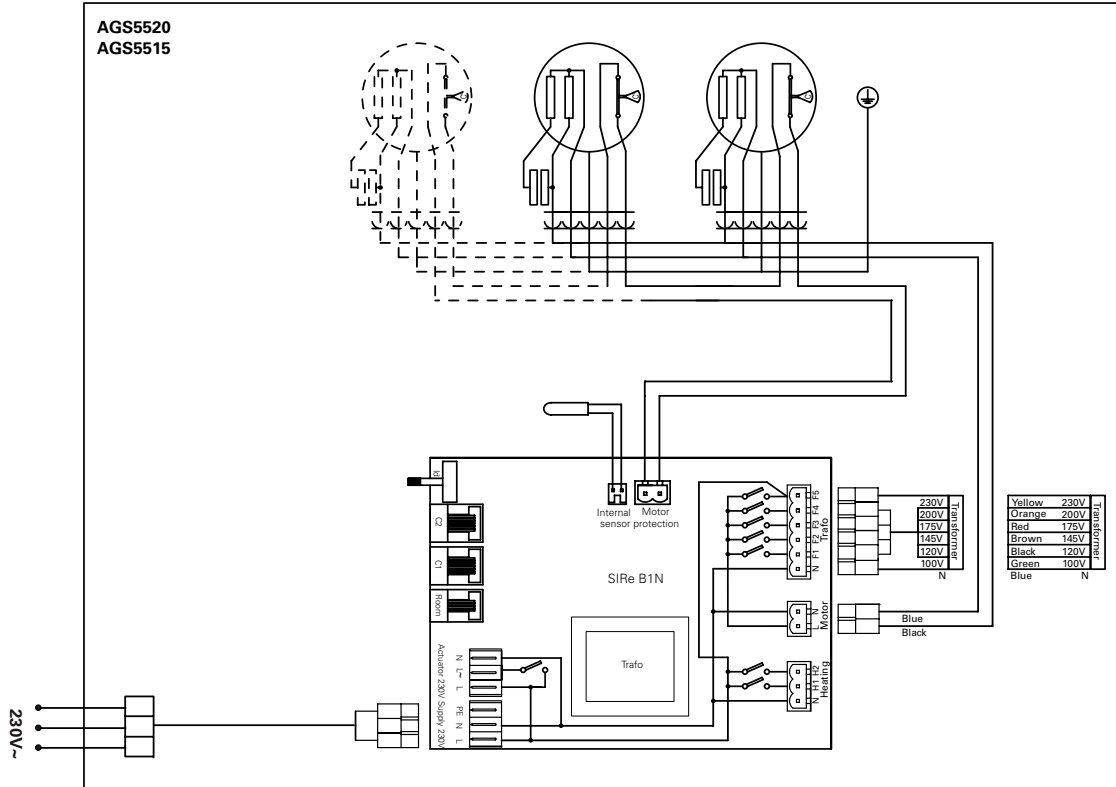

Wiring diagrams

Internal wiring diagram

AGS5525/5530

